

KENTUCKY TRANSPORTATION CENTER

College of Engineering

EVALUATION OF NON-NUCLEAR DENSITY GAUGES





UNIVERSITY OF KENTUCKY

College of Engineering
Kentucky Transportation Center

Our Mission

We provide services to the transportation community through research, technology transfer and education. We create and participate in partnerships to promote safe and effective transportation systems.

We Value...

Teamwork -- Listening and Communicating, Along with Courtesy and Respect for Others
Honesty and Ethical Behavior
Delivering the Highest Quality Products and Services
Continuous Improvement in All That We Do

For more information or a complete publication list, contact us

KENTUCKY TRANSPORTATION CENTER

176 Raymond Building
University of Kentucky
Lexington, Kentucky 40506-0281

(859) 257-4513
(859) 257-1815 (FAX)
1-800-432-0719
www.ktc.uky.edu
ktc@engr.uky.edu

The University of Kentucky is an Equal Opportunity Organization

**Research Report
KTC-03-24/FR115-01-1F**

EVALUATION OF NON-NUCLEAR DENSITY GAUGES

By

David L. Allen, P.E., P.G.

Program Manager, Pavements and Materials

David B. Schultz, Jr.

Transportation Research Engineer

And

David Allen Willett

Transportation Research Engineer

Kentucky Transportation Center
College of Engineering
University of Kentucky
Lexington, Kentucky

In cooperation with

Transportation Cabinet
Commonwealth of Kentucky

And

The Federal Highway Administration
U.S. Department of Transportation

The contents of this report reflect the views of the authors who are responsible for the facts and accuracy of the data presented herein. The contents do not necessarily reflect the views or policies of the University of Kentucky, the Kentucky Transportation Cabinet, nor the Federal Highway Administration. This report does not constitute a standard, specification, or regulation. The inclusion of manufacturer and trade names are for identification purposes and are not to be considered as endorsements.

August 2003

TABLE OF CONTENTS

1.0 INTRODUCTION	1
2.0 EQUIPMENT	2
2.1 Troxler Model 4640-B Thin-Layer Nuclear Gauge	2
2.2 PQI 300 Non-Nuclear Density Gauge	4
3.0 PROCEDURES	5
3.1 Calibration of Troxler Model 4640-B Nuclear Gauge	5
3.2 Calibration of Transtech Model PQI 300	6
3.3 Data Collection	7
4.0 DATA ANALYSIS	8
5.0 CONCLUSIONS	10
6.0 RECOMMENDATION	11
7.0 REFERENCES	11
APPENDIX	12

LIST OF FIGURES

Figure 1. Operation of Thin-Layer Gauge	3
Figure 2. Troxler Model 4640-B Nuclear Density Gauge.....	3
Figure 3. Operation of the PQI 300	4
Figure 4. Photograph of the PQI 300	5
Figure 5. Test Patterns for Special Calibration.....	6
Figure 6. Calibration Procedures in Progress.....	7
Figure 7. Distributions of Density Values	9

LIST OF TABLES

Table 1. Summary of Statistical Analysis	8
Table 2. Summary of the Significance Tests Between the Means	8

ACKNOWLEDGMENTS

We would like to extend our thanks and appreciation to the volunteers on the advisory committee for this study. Their guidance and advice during the course of this study were most helpful. We would especially like to thank Mr. Allen Myers, Chairman of the study advisory committee, for his assistance and his editing of this report. We would also like to thank the contractor personnel who assisted the research team during construction.

1.0 INTRODUCTION

For the past several decades, density of freshly laid hot mix asphalt (HMA) mats has been measured by contractors, consultants or governmental agencies using nuclear density gauges. However, use of these devices requires the user to maintain an inordinate amount of records on the use of the equipment. These requirements include calibration and recalibration records, certification records of the operators, records on radiation badges, and periodic testing of the operator's badges for radiation exposure. In addition, there is always the concern about possible accidents with the gauges that might expose the radiation source to the operators or other bystanders. Because of these issues and concerns associated with using the nuclear gauges, the contractors in Kentucky were interested in the feasibility of using other methods of measuring density for process control.

Other methods are being developed and evaluated to measure in-place density. One of the more promising ways to determine density is to measure the dielectric constant of an HMA mat by measuring its electrical "impedance" at a chosen frequency (non-nuclear density gauges). Transtech, Incorporated has developed a non-nuclear density gauge identified as a PQI Model 300 which measures the dielectric constant of an HMA mat.

The results of two previous studies on the use of the PQI 300 non-nuclear density gauge have been reported by Henault¹ and Romero². Henault reported on a study conducted by the state of Connecticut for the period of December 1999 to May 2001, using an earlier model of the PQI 300. He concluded that the PQI 300 should not be used for quality assurance (QA). Romero reported on a Pooled Fund Study conducted by the states of Maryland, Pennsylvania, New York, Connecticut, Minnesota, Oregon and the Turner-Fairbanks research laboratory of the Federal Highway Administration. The latter part of this study was conducted in 2001, after some improvements were made to the PQI 300. He concluded in his final report that the PQI 300 could be used for quality control (QC) during the paving process. However, he also concluded that the PQI 300 was not "as accurate as existing nuclear gauges."

The study described in this report was very limited in scope. The sole objective was to compare the two methods discussed above to determine if they yielded similar results when measuring density. Only one construction project was included in the study. This resurfacing project was located on Interstate 75 (Project No. IM 75-5 (27) 122, FD52 105 0075 122-136) from Milepost 124 to Milepost 135, in Scott County, Kentucky. The paving contractor was Hamilton, Hinkle and Ruth of Georgetown, Kentucky. The overlay was a 0.5-inch Superpave surface with a PG 76-22 binder. The overlay had a compacted lift thickness of 1.5 inches. The study was conducted during July and August of 2001.

2.0 EQUIPMENT

Three gauges were used in this study. The first was a Troxler, Model 4640-B, thin-layer nuclear density gauge (TMTL). The two other gauges were PQI Model 300 non-nuclear density gauges manufactured by Transtech Systems, Incorporated (mentioned previously). The first PQI 300 was operated by the contractor (HHR PQI) and the second PQI 300 was operated by the research team from the Kentucky Transportation Center (KTC PQI). The following paragraphs will give a very brief overview of the theory and operation of the two different types of gauges.

2.1 Troxler Model 4640-B Thin-Layer Nuclear Gauge

Traditional nuclear density gauges can often be inaccurate when measuring density of thin overlays. The gauge also measures the density of the underlying layer or layers, yielding erroneous results for the thin overlay. Thin-layer nuclear density gauges can overcome this problem. The theory and operation of the Troxler Model 4640-B nuclear density gauge is explained in an *Application Brief* published by Troxler Electronics, Inc.³ This publication indicates that “traditional surface moisture density gauges use a mode called nomograph mode to measure thin-layer densities. This mode requires the operator to know the density of the underlying material as well as the thickness of the overlay at the site of each measurement. These factors are used, along with the wet density determined by the gauge in the backscatter mode, to calculate the overlay density. In many cases, these factors can be difficult to determine.”

However, the thin-layer mode of the Troxler Model 4640-B measures density using two detection systems or sensors as shown in Figure 1. The first set of sensors (System 1) is located in such a manner that it “reads” backscatter from the upper layer only, while the second set of sensors (System 2) “reads” the backscatter from the lower layers. The previously referenced *Application Brief* states that “each system measures the bulk density of the material beneath the gauge. The systems themselves do not take the overlay thickness into consideration; each is influenced by varying amounts in the differing strata within the measurement material. System 1 is influenced by the uppermost portion of the material in greater proportion than is System 2. Therefore, their bulk density results can be combined numerically to calculate the overlay density.”³

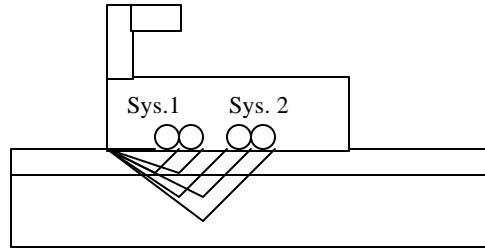

Figure 1. Operation of Thin-Layer Gauge.³

The equation for calculating density from the thin-layer mode is as follows:

$$D = [K_2(x) * DG1 - K_1(x) * DG2] / [K_2(x) - K_1(x)]$$

Where D_T = overlay density,
 x = overlay thickness,
 DG1 = System 1 bulk density, gauge measurement,
 DG2 = System 2 bulk density, gauge measurement, and
 $K_1(x)$ and $K_2(x)$ = values that are functions of the overlay thickness (x) and quantify the influences of the density of the overlay material and of the underlying material on the bulk density of the gauge.

The functional relationships of $K_1(x)$ and $K_2(x)$ with (x) are constants that are calculated during the factory calibration and entered into the machine. Figure 2 is a photograph of the thin-layer gauge used in this study.



Figure 2. Troxler Model 4640-B Nuclear Density Gauge.

2.2 PQI 300 Non-Nuclear Density Gauge

The density of an HMA mat is determined by a non-nuclear density gauge by measuring the electrical “impedance” of the material at a chosen frequency of alternating current (AC). The *impedance* of a material is defined as the resistance to flow of an AC current (this property varies with frequency). After measuring the impedance, the dielectric constant of the asphalt mat can then be determined. The *dielectric constant* is defined as the ability of a material to “store” electrostatic energy per unit of volume.

The *overall* dielectric constant of a material (such as an HMA mat) is a function of the volume of each component multiplied by its individual dielectric constant. Therefore, the relative density of a material that is composed of several components can be determined. For example, the dielectric constant of HMA, composed of aggregate and asphalt binder, is in the range of 5 to 6. However, the dielectric constant of air is 1. Therefore, a higher mat density yields a lower percentage of air, higher overall dielectric constant, and higher impedance value. Figure 3 is a diagram illustrating the operation of the PQI 300 (taken from a one-day training course⁴ developed by Transtech Systems, Incorporated, the manufacturer of the device). Figure 4 is a photograph (from the same training course) of the PQI 300.

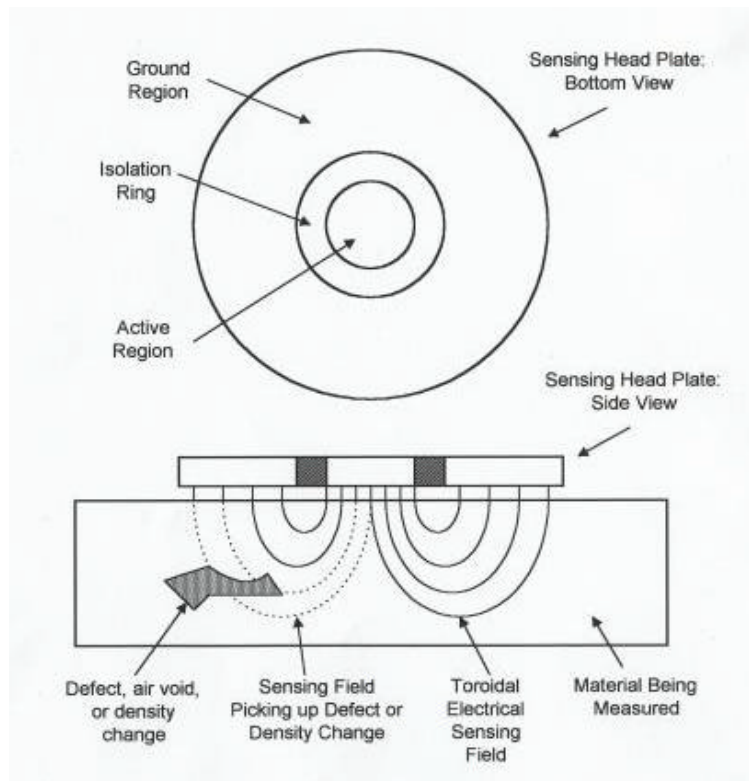

Figure 3. Operation of the PQI 300⁴.

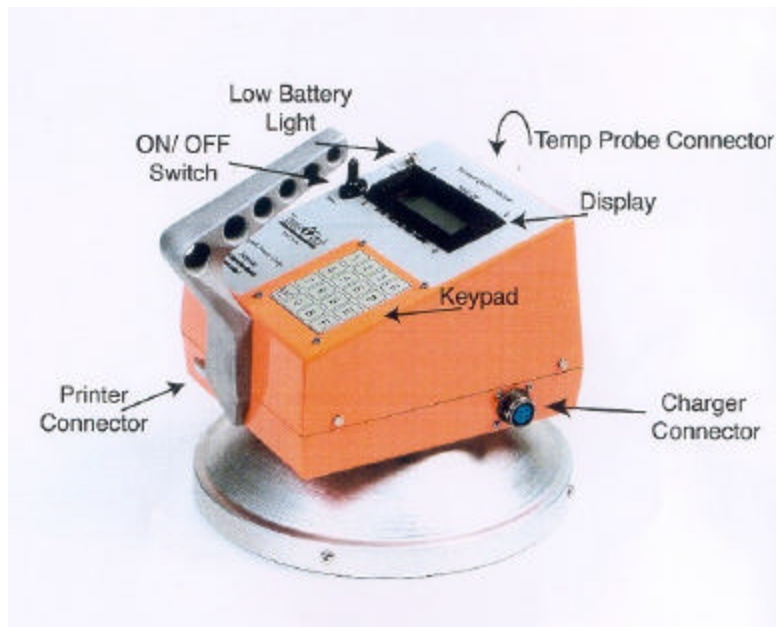

Figure 4. Photograph of the PQI 300⁴.

3.0 PROCEDURES

3.1 Calibration of Troxler Model 4640-B Thin-Layer Nuclear Gauge

According to an *Application Brief* entitled *An Instruction Guide for the Special Calibration Procedure for Troxler Thin-Layer Gauges*⁵ published by Troxler Electronics Laboratories, Incorporated, the thin-layer nuclear density gauge requires a special procedure for calibration. This calibration should be performed on the particular type of asphalt mixture to be tested. If there are changes in the characteristics of the mixture during construction, a recalibration should be performed.

When making a special calibration, it is recommended that a minimum of 12 readings be taken. Three core sites, or potential core sites, are chosen that are from two to five feet apart. This layout helps to insure that the density will be relatively uniform. The gauge is positioned on a site that will be cored, or around a site that has already been cored, as shown in Figure 5.

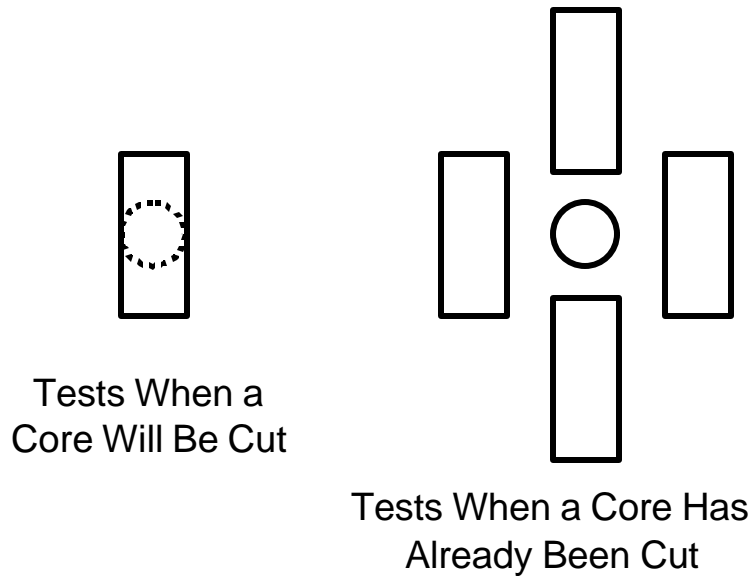

Figure 5. Test Patterns for Special Calibration⁵

It is recommended to take four one-minute readings at each core site for a total of 12 readings. When readings are being taken at a site where a core is to be obtained in the future, after two readings, the gauge should be turned 180°. In this study, the Troxler nuclear density gauge was calibrated according to this procedure. More detailed information on calibration can be obtained from the above-referenced *Application Brief*.

3.2 Calibration of Transtech Model PQI 300

In general, the calibration procedure for the PQI 300 non-nuclear density gauge is as follows (as detailed in Reference No. 4):

1. Identify a minimum of five test locations within a 10-foot area on the compacted HMA.
2. Place the PQI device on the HMA mat, and draw a circle around the probe of the unit.
3. Record a minimum of five single-shot readings with the PQI device within the drawn circle using a clockwise motion. Move the PQI device at least two inches between readings.
4. Record the readings.
5. Cut a six-inch core from the center of the marked circle. Repeat this process for the four additional test locations.

6. Perform the density measurements on the cores in the laboratory and record the results.
7. Compare the readings obtained with the PQI device and the cores.
8. Note the numeric difference between the average PQI device readings to the average core density.
9. Add or subtract the numeric difference from the offset number found in the PQI device under the calibration menu.

This process essentially completes the calibration of the PQI device. Again, more detail on the theory, operation and calibration of the PQI 300 can be found in Reference No. 4. Figure 6 shows calibration procedures in progress for this unit.



Figure 6. Calibration Procedures in Progress.

3.3 Data Collection

As previously indicated, the field testing for this study was performed from Mileposts 124 to 135 on Interstate 75 in Scott County, Kentucky. Core and plant-produced HMA field data were available for Lots 3 through 13. In general, four cores were collected for each subplot (four sublots per lot). However, Sublots 4-4 and 7-2 had only three cores, and Sublots 7-4, 8-4, and 13-4 had only one core. All of the data collected in this study are shown in the appendix.

In general, at each location where a core was to be collected, five readings each were taken with the HHR PQI and the KTC PQI. In addition, from one to four readings were taken with the TMTL. Temperature of the HMA mat was not

recorded because the PQI 300 is self-compensating for temperature. The effects of magnetic fields on the PQI 300 were not known and were not studied in this research effort; however, care was taken during the field testing to avoid using the device near power lines.

4.0 DATA ANALYSIS

A standard statistical analysis was performed on the data listed in the appendix. Table 1 shows the results of that analysis. The cores were used as the “standard” in this study because pay factors are based on core densities. Therefore, data from each of the density gauges were compared to core data.

Table 1. Summary of Statistical Analysis.

	Machine Used			Cores
	HHR PQI	KTC PQI	TMTL	
Number of Readings or Cores	735	740	453	149
Average (lb/ft³)	144.4	143.4	142.3	144.1
Standard Deviation (lb/ft³)	4.91	3.52	4.15	2.72

The HHR PQI had the highest mean, and the TMTL had the lowest. Also, the HHR PQI had the highest standard deviation (most scatter in the data) while the cores had the lowest (most uniform). To determine if the difference between the means is significant, a standard *two-sample, t-test for means* was performed at the 5% significance level. The mean for each of the density gauges was compared to the mean of the cores. The results are listed in Table 2.

Table 2. Summary of the Significance Tests Between the Means.

	P – value	Comment	95% Confidence Interval for Difference Between the Two Means
HHR PQI with Cores	0.4107	Not Significant	-1.05 to 0.58
KTC PQI with Cores	0.0026	Significant	0.18 to 1.38
TMTL with Cores	<0.0001	Significant	1.12 to 2.54

For the difference between the means to be *not significant*, the P-value in Table 2 must be equal to, or greater than, 0.05. Clearly, only the difference between the means of the HHR PQI and the cores was not significant.

An additional analysis can be performed to determine the similarities of the distributions of the four data sets. If the data are plotted as shown in Figure 7, the percentage of the overlap of the different distributions can be calculated.

Distribution of Density Values

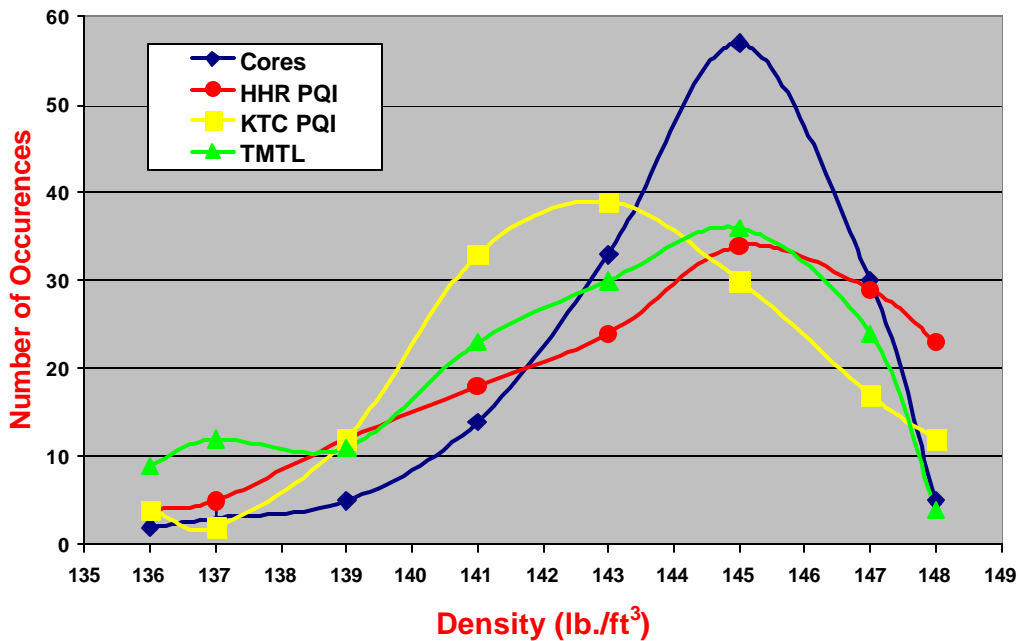

Figure 7. Distributions of Density Values.

Clearly, all of the density gauges had higher standard deviations than the cores, as illustrated by the “broader” distributions in Figure 7 and listed in Table 1. To determine which gauge had a distribution that was most “similar” to the distribution of the cores, the area under the distribution curve was calculated for each density gauge and for the cores. The portion of the area under the distribution curve for each gauge that did not overlap the distribution curve for the cores was subtracted from the total area under the curve to yield the percent overlap. The results of that analysis are as follows:

HHR PQI 88%,
TMTL 83%, and
KTC PQI 78%.

Therefore, the distribution of density readings from the HHR PQI gauge was the most “similar” to the distribution of density readings obtained from the cores. An alternate way of expressing the same concept would be to assume an individual is interested in determining if a particular density reading was from the HHR PQI gauge or from a core value. From the data above, it could be said that there was an 88 percent probability that the density value could be from *either* distribution (from the HHR PQI or from cores). In this study, the “perfect” distribution would be 100%, which would indicate that both distributions were exactly the same.

It should be noted in Figure 7 that the “mode” (peak of the distribution curve) of the KTC PQI is displaced from the mode of the other density gauges and the cores by approximately two pounds per cubic foot. This displacement indicates a “systematic” error in the readings from the KTC PQI gauge which, in turn, indicates the possibility of a calibration error in that device.

Although pay factors are based on core densities, it was decided to examine pay factors based on density readings from the gauges to determine the percent of maximum theoretical density (percent density) calculated from the maximum specific gravity for each subplot. The overall average percent density from each gauge and from the cores is as follows:

HHR PQI	92.9,
KTC PQI	92.1,
TMTL	91.7, and
Cores	92.8.

In Kentucky, 100 percent pay is from 92.0 to 93.9 percent density, and 95 percent pay is from 91.0 to 91.9 percent density. Therefore, if pay factors were based on gauge readings, using the TMTL gauge would have resulted in 95% pay for lane density. The HHR PQI and KTC PQI gauges would have resulted in 100% pay.

5.0 CONCLUSIONS

1. The standard deviations of the density readings of all the gauges were greater the standard deviation of the overall density of the cores. This information indicates that there was more “scatter” in the data from each of the gauges than in the core data. This relationship is illustrated in Figure 7 by the “broader” distribution functions of the gauges.
2. There was no significant difference between the mean density of the HHR PQI and the mean density of the cores. However, there was a statistically significant difference between the mean density of the TMTL and KTC PQI density gauges and the cores.
3. The density distribution of the HHR PQI gauge most closely matched the distribution of the cores with an 88% overlap in the distributions. The TMTL gauge and KTC PQI gauge had overlaps in their density distribution functions with the density distribution function of the cores of 83% and 78%, respectively. This information indicates that the HHR PQI gauge, not only in the mean density but also in the overall distribution of readings, most closely approximated the results from the cores.

4. If pay factors were determined from gauge densities, then using the densities provided by the TMTL gauge would have resulted in a five-percent reduction in overall pay for lane densities. On hundred percent overall pay would have resulted from using the two non-nuclear density gauges.

6.0 RECOMMENDATION

This recommendation is based solely on the data obtained from this study. Because the ease of operation and calibration of the two types of gauges are similar, and because the gauge that most closely approximated the data from the cores (both by comparing the means and distributions) was the HHR PQI non-nuclear gauge, it is the authors' opinion that non-nuclear density gauges can be used for quality control on HMA paving mats without sacrificing density or quality. It is recommended that non-nuclear density gauges be permitted for use in quality control for density on HMA paving projects.

7.0 REFERENCES

1. Henault, J. W., *Field Evaluation of a Non-Nuclear Density Pavement Quality Indicator*, Report No. 2227-F-01-3, Connecticut Department of Transportation, Bureau of Engineering and Highway Operations, Division of Research, June 2001.
2. Romero, P., *Evaluation of Non-Nuclear Gauges to Measure Density of Hot-Mix Asphalt Pavements*, Pooled Fund Study, Final Report, University of Utah, Department of Civil and Environmental Engineering, July 2002.
3. *Thin-Layer Overlay Density Measurement*, Application Brief, Troxler Electronic Laboratories, Incorporated, Research Triangle Park, NC, August 1998.
4. *Pavement Quality Indicator*, One-Day User Training Program, Transtech Systems, Incorporated, Schenectady, NY.
5. *An Instruction Guide for the Special Calibration Procedure for Troxler Thin-Layer Gauges*, Troxler Electronic Laboratories, Incorporated, Research Triangle Park, NC, October 1998.

**APPENDIX
FIELD DATA**

Non-Nuclear Test Project																						
Interstate-75 MP 124 to 135																						
(All Densities Are in Units of lb/ft ³)																						
CORE LABEL	MSG of SUBLOT	BSG of CORE	CORE NSITY (lbs)	HHR PQI 300 Density Measurements (lbs/ft ³)							Average Moisture	KTC PQI 300 Density Measurements (lbs/ft ³)					Average Moisture	Trolox 4640-B Density Measurements				
				Reading 1	Reading 2	Reading 3	Reading 4	Reading 5	Reading 1	Reading 2		Reading 3	Reading 4	Reading 5	Reading 1	Reading 2		Reading 3	Reading 4	Reading 5		
3-2-A	2.506	2.302	143.6	143.5	140.7	143.0	143.0	144.0	142.8	NA	144.4	144.3	144.4	142.6	145.3	144.2		143.2	143.4		143.3	
3-2-B	2.506	2.305	143.8	139.2	139.5	138.9	138.6	138.3	138.9	6	144.9	144.5	145.7	147.2	142.9	145.0	8.2	141.7			141.7	
3-2-C	2.506	2.306	143.9	143.3	143.1	143.1	143.1	145.8	144.5	4.6	144.1	145.2	145.1	145.7	144.1	144.8	7.0	144.0			144.0	
3-2-D	2.506	2.363	147.5	147.1	147.1	147.9	146.9	147.0	147.2	4	147.8	147.3	148.1	148.9	148.6	148.1	6.2	146.9			146.9	
3-3-A	2.461	2.368	147.8	145.7	147.4	146.5	144.9	146.2	146.1	4.4	145.5	146.9	144.5	146.2	146.5	145.9	6.6	149.7			149.7	
3-3-B	2.461	2.377	148.3	148.1	148.5	148.4	147.9	144.5	147.5	5.8	148.3	149.8	148.5	145.9	150.1	148.5	7.8	146.6			146.6	
3-3-C	2.461	2.333	145.6	142.7	142.8	142.7	143.5	144.4	143.2	4.9	143.9	144.1	143.9	144.2	145.3	144.3	6.7	143.1			143.1	
3-3-D	2.461	2.331	145.5	146.4	147.3	146.9	145.4	148.6	146.9	5.3	148.2	146.8	147.9	148.0	147.0	147.6	7.4	144.4			144.4	
3-4-A	2.505	2.234	139.4	143.9	144.8	145.0	146.5	143.1	144.7	7.6	145.6	147.4	146.0	145.1	146.4	146.1	8.6	142.1			142.1	
3-4-B	2.505	2.279	142.2	147.8	144.9	142.3	143.8	143.2	144.4	8.5	148.1	142.4	140.4	145.7	145.5	144.4	10.1	144.8			144.8	
3-4-C	2.505	2.255	140.7	138.7	139.4	138.2	139.9	140.8	139.4	6.7	140.5	140.8	139.9	141.1	142.0	140.9	9.1	142.1			142.1	
3-4-D	2.505	2.307	144.0	146.3	144.2	144.2	146.0	145.0	145.1	4.7	145.7	144.2	144.1	146.2	145.0	145.0	7.0	146.9			146.9	
4-1-A	2.505	2.345	146.3	149.2	149.4	148.5	148.9	147.0	148.6	4.8	149.1	148.8	148.1	148.9	147.6	148.5	6.1	147.2			147.2	
4-1-B	2.505	2.274	141.9	139.8	138.5	140.0	143.1	141.5	140.6	3.7	141.3	140.3	140.8	142.8	142.9	141.6	5.8	140.3			140.3	
4-1-C	2.505	2.366	147.6	145.3	145.9	145.4	144.7	145.1	145.3	3.3	144.1	143.9	143.7	143.9	144.0	143.9	5.5	146.2			146.2	
4-1-D	2.505	2.339	146.0	153.9	150.7	152.6	153.8	152.1	152.6	4.5	153.9	150.9	153.2	154.2	152.6	153.0	6.1	145.8			145.8	
4-4-B	2.485	2.364	147.5	145.7	142.7	147.1	147.2	141.0	144.7	3.5	132.4	137.4	142.9	138.2	133.8	136.9	5.8	143.9	144.5	143.7	144.0	
4-4-C	2.485	2.334	145.6	90.7	141.7	144.0	143.0	142.6	132.4	4	142.0	144.7	142.3	140.4	140.7	142.0	6.4	145.9	146.5	146.6	146.3	
4-4-D	2.485	2.330	145.4	144.0	143.5	145.9	143.8	146.5	144.7	3.4	143.4	144.3	140.1	143.2	143.6	142.9	5.4	144.9	144.5	144.8	144.7	
5-1-A	2.500	2.320	144.8		146.9	147.0	147.2	147.9	147.3	3.1	141.9	143.1	143.3	143.2	143.4	143.0	5.0	146.8	144.9	146.4	146.0	
5-1-B	2.500	2.304	143.8	136.1	145.0	146.7	138.9	145.1	142.4	3.5	143.1	139.4	144.0	138.5	137.7	140.5	5.4	139.7	141.0	141.2	140.6	
5-1-C	2.500	2.366	147.6	150.9	151.4	150.7	152.7	151.9	151.5	5	145.5	147.4	148.0	150.1	147.7	147.7	6.9	144.2	144.6	144.8	144.5	
5-1-D	2.500	2.317	144.6	145.8	143.3	142.2	147.7	145.4	144.9	3.9	139.2	139.6	139.7	136.5	139.3	138.9	6.0	139.4	140.9	139.7	140.0	
5-2-A	2.490	2.281	142.3	139.7	144.4	140.5	141.5	141.5	141.5	5.1	141.4	141.5	138.8	139.7		140.4	7.5	136.9	137.4	137.1	137.1	
5-2-B	2.490	2.365	147.6	148.8	149.6	143.7	146.8	140.8	145.9	4	144.2	145.4	144.4	146.8		145.2	5.9	146.5	147.3	146.9	146.9	
5-2-C	2.490	2.313	144.3	144.6	143.7	142.5	141.5	145.6	143.6	3.9	140.5	142.5	142.2	141.7	140.1	141.4	6.5	145.5	145.0	146.4	145.6	
5-2-D	2.490	2.317	144.6	144.4	142.6	145.5	144.0	144.8	144.3	3	141.0	141.6	140.3	142.2	140.8	141.2	5.0	144.3	144.7	145.2	144.7	
5-3-A	2.487	2.235	139.5	139.7	140.1	141.8	141.1	139.6	140.5	4.6	138.0	139.2	139.6	137.6	137.6	138.4	7.3	138.7	136.5	137.7	137.6	
5-3-B	2.487	2.299	143.5	146.3	143.6	146.5	147.2	145.2	145.8	5.2	144.2	141.8	144.3	146.1	142.8	143.8	7.3	143.2	142.8	143.8	143.3	
5-3-C	2.487	2.321	144.8	149.7	150.0	150.4	151.0		150.3	3.3	147.1	147.0	147.8	147.5	146.0	147.1	5.2	143.6	144.6	143.4	143.9	
5-3-D	2.487	2.319	144.7	147.1	149.0	148.6			148.2	5.2	144.5	145.7	137.5	143.6	145.0	143.3	7.3	146.2	145.9	145.0	145.7	
5-4-A	2.496	2.344	146.3	149.4	150.3	144.1	148.2	150.5	148.5	4.5	147.0	144.3	146.9	146.5	145.6	146.1	6.7	147.7	147.7	147.5	147.6	
5-4-B	2.496	2.307	144.0	145.7	145.9	145.7	143.7	146.7	145.5	3.4	142.3	140.4	140.3	143.0	142.1	141.6	5.6	142.4	142.8	142.9	142.7	
5-4-C	2.496	2.330	145.4	147.7	146.9	146.3	144.5	146.9	146.5	5.3	145.2	143.9	144.6	143.7	144.1	144.3	6.9	146.6	145.8	146.2	146.2	
5-4-D	2.496	2.254	140.6	145.3	146.4	145.3	145.7	145.1	145.6	3	143.5	143.6	144.7	140.9	143.2	143.2	5.0	141.4	142.1	141.3	141.6	
6-1-A	2.476	2.321	144.8	146.6	147.6	141.4	150.0	149.7	147.1	5.8	149.8	145.8	146.6	149.3	147.7	147.8	7.4	147.0	146.9	146.2	146.7	
6-1-B	2.476	2.327	145.2	149.6	149.8	149.6	147.7	148.4	149.0	5.4	148.0	147.8	147.9	144.8	146.0	146.9	7.4	144.2	145.3	145.4	145.0	
6-1-C	2.476	2.284	142.5	144.4	144.0	144.3	148.1	147.3	145.6	5.4	143.2	142.6	141.7	145.5	145.6	143.7	7.5	134.9	134.8	139.6	136.4	
6-1-D	2.476	2.287	142.7	148.0	148.2	144.2	148.3	148.6	147.5	5.4	145.9	147.5	146.9	147.8	141.2	145.9	7.4	142.8	143.5	143.8	143.4	
6-2-A	2.482	2.212	138.0	145.5	146.3	146.9	145.9	140.2	145.0	14	139.2	138.6	142.0	139.9	139.6	139.9	15.1	136.3	135.9	137.0	136.4	
6-2-B	2.482	2.335	145.7	152.2	143.1	155.3	155.4		151.5	12.4	146.1	146.6	149.8	149.6	143.5	147.1	13.4	145.7	146.1	145.3	145.7	
6-2-C	2.482	2.332	145.5	141.0	144.1	147.6	145.4	142.5	144.1	10.5	143.2	144.8	141.4	143.3	142.3	143.0	13.2	143.8	142.7	143.7	143.4	
6-2-D	2.482	2.337	145.8	144.5	141.9	150.0	135.9	147.2	143.9	11.5	142.3	140.6	142.3	143.9	136.9	141.2	13.4	144.8	145.4	145.3	145.2	
6-3-A	2.478	2.280	142.3	148.0	151.2	154.1	150.5	151.0	151.0	16.6	140.2	146.0	140.2	144.9		142.8	16.4	139.7	139.4	140.2	139.8	
6-3-B	2.478	2.285	142.6	151.3	153.8	150.6	149.7	154.8	152.0	16.3	144.3	146.6	144.0	146.7	147.5	145.8	17.5	138.1	138.3	142.1	139.5	
6-3-C	2.478	2.302	143.6	142.7	141.7	141.1	145.3	143.8	142.9	4.4	140.9	141.6	140.9	140.1	141.0	140.9	6.2	145.4	145.2	146.4	145.7	
6-3-D	2.478	2.345	146.3	151.8	152.5	148.9	152.1	152.0	151.5	5.2	147.8	146.7	148.4	148.2	146.9	147.6	6.9	147.3	147.5	147.4	147.4	
6-4-A	2.491	2.344	146.3	146.9	147.2	144.2	147.5	148.2	146.8	4.9	142.2	142.3	142.1	141.5	141.9	142.0	6.7	149.9	149.0	149.6	149.5	
6-4-B	2.491	2.329	145.3	148.2	148.8	148.2	148.2	148.4	148.4	5.1	145.6	144.7	146.6	146.0	145.4	145.7	6.8	144.3	145.1	144.6	144.7	
6-4-C	2.491	2.334	145.6	153.9	151.0	150.7	150.5	148.1	150.8	6.2	150.0	148.5	147.7	147.6	146.5	148.1	8.2	145.4	145.8	146.1	145.8	
6-4-D	2.491	2.341	146.1	153.1	155.3	150.6	150.7	154.8	152.9	6.4	149.7	152.7	147.9	147.3	151.6	149.8	8.0	145.1	146.6	146.1	145.9	
7-1-A	2.480	2.350	146.6	149.7	146.9	145.4	146.6	147.6	147.2	4	144.6	143.2	140.9	143.4	143.5	143.1	6.2	145.6	146.8	145.6	146.0	
7-1-B	2.480	2.328	145.3	147.5	146.8	145.5	146.2	147.3	146.7	7.2	145.1	143.7	141.1	141.5	140.3	142.3	9.1	144.4	144.0	145.3	144.6	
7-1-C	2.480	2.308	144.0	148.7	146.6	148.5	147.4	147.5	147.7	4.9	145.2	145.3	144.6	145.3	144.9	145.1	6.7	142.7	142.8	142.6	142.7	
7-1-D	2.480	2.258	140.9	144.0	142.4	144.2	144.9	144.0	143.9	3.4	140.6	140.8	140.0	141.0	141.4	140.8	5.6	136.7	137.5	138.4	137.5	

Non-Nuclear Test Project																								
Interstate-75 MP 124 to 135																								
(All Densities Are in Units of lb/ft ³)																								
CORE LABEL	MSG of SUBLOT	BSG of CORE	CORE NSITY (lbs)	HHR PQI 300 Density Measurements (lbs/ft ³)							Average Moisture	KTC PQI 300 Density Measurements (lbs/ft ³)							Average Moisture	Troxler 4640-B Density Measurements				
				Reading 1	Reading 2	Reading 3	Reading 4	Reading 5	Average	Reading 1		Reading 2	Reading 3	Reading 4	Reading 5	Average	Reading 1	Reading 2		Reading 3	Reading 4	Average		
7-2-A	2.501	2.300	143.5	146.4	146.6	148.9	146.6	148.8	147.5	4.3	143.2	146.2	144.4	144.7	144.6	144.6	6.3	141.8	141.9	142.8	142.2			
7-2-B	2.501	2.372	148.0	153.5	151.4	152.4	153.6	152.6	152.7	5.3	149.5	148.4	147.3	150.4	148.1	148.7	7.2	148.1	148.2	148.6	148.3			
7-2-C	2.501	2.301	143.6	146.6	147.3	149.4	147.5	144.1	147.0	4	144.4	141.8	142.1	146.5	142.0	143.4	6.2	142.9	142.2	142.7	142.6			
7-4-D	2.504	2.363	147.5	140.6	141.7	141.4	139.8	140.5	140.8	6.3	142.1	143.3	142.7	140.7	141.4	142.0	7.9	139.8	140.2	139.7	139.9			
8-1-A	2.490	2.315	144.5	144.2	143.5	144.9	143.5	140.9	143.4	5.1	144.7	143.7	144.9	143.8	143.9	144.2	7	146.3	146.3	146.9	146.5			
8-1-B	2.490	2.308	144.0	149.1	150.5	146.4	148.1	149.0	148.6	5.2	150.5	150.7	150.6	150.7	150.3	150.6	6.7	145.0	144.2	144.7	144.6			
8-1-C	2.490	2.340	146.0	146.6	144.7	144.0	145.2	143.9	144.9	6	148.2	147.9	146.9	147.0	146.1	147.2	8	147.1	147.6	147.0	147.2			
8-1-D	2.490	2.316	144.5	141.4	140.5	140.1	139.4	140.0	140.3	5.2	145.0	143.7	143.2	142.1	142.1	143.2	7.2	137.5	138.6	137.8	138.0			
8-2-A	2.497	2.323	145.0	145.7	145.0	146.1	145.7	144.7	145.4	6.1	146.6	147.3	147.2	144.9	145.1	146.2	7.9	145.9	145.6	145.7	145.7			
8-2-B	2.497	2.300	143.5	135.2	136.7	135.3	136.7	136.6	136.1	5.9	135.3	137.1	134.0	134.7	136.1	135.4	7.9	132.9	132.9	132.5	133.6			
8-2-C	2.497	2.270	141.6	141.9	140.8	141.7	143.9	142.1	142.1	7.1	140.6	140.0	140.0	141.3	141.7	140.7	8.9	141.7	140.1	140.0	141.6			
8-2-D	2.497	2.274	141.9	144.4	143.5	142.8	144.0	141.4	143.2	4.8	142.7	141.4	141.7	141.0	139.8	141.3	6.8	141.8	141.0	141.3	140.9			
8-3-A	2.493	2.337	145.8	143.9	147.6	149.1	145.9	145.7	146.4	4.7	142.4	146.3	143.9	143.4	144.5	144.1	6.6	145.2	145.3	144.9	144.4			
8-3-B	2.493	2.285	142.6	142.9	140.8	145.0	145.6	144.7	143.8	4.8	141.4	139.6	142.9	143.8	142.8	142.1	6.8	135.5	133.4	140.3	140.3			
8-3-C	2.493	2.366	147.6	151.4	150.3	151.1	151.3	150.2	150.9	5.2	146.9	146.3	147.2	146.6	146.9	146.8	7.3	147.8	147.7	147.4	149.8			
8-3-D	2.493	2.350	146.6	156.4	156.5	158.6	151.1	155.8	155.7	6.5	153.0	154.1	155.5	149.6	152.9	153.0	7.8	147.4	145.9	146.3	145.0			
8-4-D	2.481	2.199	137.2	141.7	141.1	142.2	140.5	140.8	141.3	4.5	140.4	140.6	140.0	139.3	140.3	140.1	6.8	137.3			137.3			
9-1-A	2.513	2.272	141.8	146.9	144.2	147.4	147.4	145.1	146.2	3.5	145.2	142.6	145.3	145.5	142.2	144.2	5.5	140.8			140.8			
9-1-B	2.513	2.306	143.9	144.8	146.4	144.2	145.5	144.1	145.0	5.1	142.2	144.4	142.2	142.6	143.8	143.0	7.3	144.2	143.6		143.9			
9-1-C	2.513	2.184	136.3	133.8	131.5	131.4	131.7	128.2	131.3	4.2	135.5	135.1	134.8	135.8	134.7	135.2	6.5	133.7	131.9	129.5	131.7			
9-1-D	2.513	2.350	146.6	148.2	145.2	147.1	141.6	139.2	144.3	5.2	148.4	146.7	147.9	144.3	142.7	146.0	7.1	147.7	146.6	147.9	146.6			
9-2-A	2.492	2.116	132.0	129.9	129.4	133.1	132.1	131.5	131.2	3.4	134.0	134.2	135.5	134.6	134.5	134.6	5.5	124.4	126.3	126.6	125.8			
9-2-B	2.492	2.116	132.0	131.0	131.6	131.6	129.8	131.4	131.1	4.4	133.6	133.4	134.4	132.6	133.6	133.5	7.1	126.9	126.5	126.8	124.1			
9-2-C	2.492	2.233	139.3	137.7	139.0	138.9	137.5	136.9	138.0	4.4	139.6	140.2	140.2	139.6	140.3	140.0	6.9	136.4	136.3	135.7	132.4			
9-2-D	2.492	2.374	148.1	136.8	142.2	139.6	139.5	139.0	139.4	4.3	140.9	143.0	141.1	141.1	140.3	141.3	6.4	136.0	137.8	136.8	135.7			
9-3-A	2.487	2.323	145.0	141.0	139.3	139.9	140.9	142.7	140.8	4.6	141.1	143.1	141.6	143.8	146.3	143.2	6.9	147.1			147.1			
9-3-B	2.487	2.356	147.0	138.3	138.8	140.7	138.1	137.3	138.6	4.1	137.8	139.6	139.7	139.7	139.0	139.2	6.5	138.6	142.0		140.3			
9-3-C	2.487	2.287	142.7	136.9	137.4	137.9	135.7	136.6	136.9	3.3	138.1	137.9	138.2	137.4	137.5	137.8	5.6	134.7	135.9	134.1	134.9			
9-3-D	2.487	2.338	145.9	144.3	142.3	141.7	144.4	142.6	143.1	5	145.3	142.1	142.5	144.6	142.6	143.4	7.2	146.4			146.4			
9-4-A	2.494	2.275	142.0	143.8	144.2	144.2	141.4	135.9	141.9	5.8	136.8	143.8	144.0	134.1	138.9	139.5	8	131.2			131.2			
9-4-B	2.494	2.301	143.6	145.9	141.7	142.6	142.9	141.5	142.9	3.9	145.1	142.3	142.8	142.9	141.9	143.0	6.2	146.2			146.2			
9-4-C	2.494	2.321	144.8	148.0	146.4	146.4	147.0	147.8	147.1	4.2	147.5	147.6	146.7	146.7	148.0	147.3	6.3	146.6			146.6			
9-4-D	2.494	2.315	144.5	144.7	147.2	145.9	146.4	145.0	145.8	4.7	146.0	146.2	144.9	142.4	141.0	144.1	7	142.3	144.4	140.3	142.3			
10-1-A	2.484	2.326	145.1	144.1	140.3	145.1	143.6	145.0	143.6	5	142.7	143.8	135.6	143.0	144.4	141.9	7.5	143.9			143.9			
10-1-B	2.484	2.235	139.5	138.6	138.9	140.8	137.3	139.5	139.0	4.6	140.0	140.2	141.5	138.2	140.3	140.0	7	136.7			136.7			
10-1-C	2.484	2.322	144.9	141.6	143.5	144.1	141.9	148.2	143.9	4.6	141.5	142.3	142.3	141.3	147.1	142.9	6.9	144.6			144.6			
10-1-D	2.484	2.310	144.1	144.3	147.7	147.9	144.7	144.5	145.8	4.3	145.2	147.4	147.2	144.5	144.0	145.7	6.8	142.8			142.8			
10-2-A	2.485	2.316	144.5	144.9	146.9	146.9	144.2	144.9	145.6	4.5	144.5	146.1	146.2	144.6	145.7	145.4	6.6	143.8			143.8			
10-2-B	2.485	2.270	141.6	142.4	142.9	142.8	139.5	142.5	142.0	4.6	143.1	143.0	143.2	140.7	142.8	142.6	6.7	138.9			138.9			
10-2-C	2.485	2.288	142.8	132.7	142.1	142.2	143.1	141.2	140.3	4.9	142.7	143.1	143.1	143.7	143.4	143.2	7.5	143.8	143.7	143.7	144.1			
10-2-D	2.485	2.384	148.8	143.5	144.5	145.1	143.2	143.2	143.9	5.6	140.7	143.8	138.9	139.0	144.4	141.4	7	140.1	139.2	141.4	140.4			
10-3-A	2.493	2.323	145.0	146.2	145.2	152.4	148.1	148.6	148.1	6.5	145.2	145.7	148.8	147.4	148.3	147.1	8	146.1	145.1	146.2	145.8			
10-3-B	2.493	2.314	144.4	147.9	144.6	146.4	146.5	143.8	145.8	5.3	147.2	144.8	142.5	146.6	144.1	145.0	7.5	145.8	145.2	144.9	144.8			
10-3-C	2.493	2.366	147.6	138.3	139.9	140.5	137.3	138.3	138.9	5.1	139.0	141.1	141.2	139.1	139.9	140.1	7.5	138.6	137.1	136.4	137.4			
10-3-D	2.493	2.371	148.0	136.3	141.8	134.4	135.4	136.6	136.9	4.4	140.4	140.5	141.0	141.2	141.0	140.8	7.5	140.1	138.6	139.3	140.8			
10-4-A	2.481	2.313	144.3	142.2	138.0	141.7	141.7	142.8	141.3	4.6	141.6	140.0	141.6	140.9	141.3	141.1	7.2	137.8	138.8	137.5	138.9			
10-4-B	2.481	2.358	147.1	143.7	142.3	143.7	147.5	146.5	144.7	4.6	144.8	143.9	146.3	146.4	143.8	145.0	7.1	142.3	142.8	141.4	143.7			
10-4-C	2.481	2.362	147.4	141.2	143.0	141.2	139.3	140.9	141.1	4.5	140.4	142.0	139.5	139.9	142.6	140.9	6.6	134.6	134.9	128.4	141.6			
10-4-D	2.481	2.331	145.5	150.9	150.1	150.2	152.0	152.3	151.1	5.8	148.4	149.8	148.9	149.8	148.6	149.1	7.7	146.9	147.4	146.8	147.3			
11-1-A	2.482	2.209	137.8	144.7	144.3	144.8	146.6	144.9	145.1	7.7	146.7	146.6	146.2	148.0	147.4	147.0	6.4	138.4	139.2	139.3	137.3			
11-1-B	2.482	2.308	144.0	139.3	140.5	139.0	138.8	139.5	139.4	8	142.7	143.3	142.5	142.3	142.4	142.6	6.3	141.4	139.8	141.6	141.7			
11-1-C	2.482	2.338	145.9	143.7	142.9	141.9	141.7		142.6	6.3	139.9	140.0	138.5	139.5	141.6	139.9	8.5	140.2	140.5	140.0	141.4			
11-1-D	2.482	2.316	144.5	141.1	139.6	139.8	140.6	141.9	140.6	6.1	139.0	138.4	138.4	138.2	138.2	138.4	7.9	137.9	137.5	136.4	138.3			
11-2-A	2.497	2.294	143.1	147.0	145.8	144.5	144.9	145.3	145.5	5.4	143.4	140.2	142.7	142.4	141.0	141.9	7.1	142.6	142.9	140.9	141.7			
11-2-B	2.497	2.339	146.0	147.4	145.8	148.4	146.9	146.2	146.9	3.9	143.9	141.8	142.5	143.8	145.3	143.5	5.6	145.0	144.6	144.5	144.2			

</

Non-Nuclear Test Project																						
Interstate-75 MP 124 to 135																						
(All Densities Are in Units of lb/ft ³)																						
CORE LABEL	MSG of SUBLOT	BSG of CORE	CORE DENSITY (lbs)	HHR PQI 300 Density Measurements (lbs/ft ³)							Average Moisture	KTC PQI 300 Density Measurements (lbs/ft ³)					Average Moisture	Troloxler 4640-B Density Measurements				
				Reading 1	Reading 2	Reading 3	Reading 4	Reading 5	Average	Reading 1		Reading 2	Reading 3	Reading 4	Reading 5	Average		Reading 1	Reading 2	Reading 3	Reading 4	Average
11-4-A	2.482	2.322	144.9	146.0	149.4	145.5	148.1	147.3	4.8	143.0	145.8	143.6	144.8	144.5	144.3	6.6	145.0	144.2	144.0	145.2	144.6	
11-4-B	2.482	2.331	145.5	148.4	147.4	147.1	147.8	148.8	4.8	144.7	144.6	143.9	145.2	144.4	144.6	6.7	146.7	147.2	147.5	146.5	147.0	
11-4-C	2.482	2.331	145.5	147.4	145.6	145.6	148.0	146.5	4.5	144.1	144.2	144.5	143.3	143.3	143.9	6.5	146.1	145.1	145.7	146.5	145.9	
11-4-D	2.482	2.343	146.2	146.9	147.1	146.6	142.9	146.2	5.5	144.2	144.5	143.9	141.1	143.7	143.5	7.3	141.8	141.0	140.6	140.8	141.1	
12-1-A	2.480	2.343	146.2	152.7	150.2	151.6	148.6	147.1	4.5	150.2	149.5	150.6	147.0	144.8	148.4	6.4	142.9	141.0	142.5	141.5	142.0	
12-1-B	2.480	2.282	142.4	147.3	146.5	146.5	145.1	145.2	5.2	144.7	144.8	143.6	144.6	142.5	144.0	7.4	143.1	143.2	144.4	142.7	143.4	
12-1-C	2.480	2.264	141.3	144.0	142.4	142.1	143.9	143.6	4.3	141.7	141.7	140.4	141.6	141.6	141.4	7.1	142.3	141.6	141.9	142.9	142.2	
12-1-D	2.480	2.298	143.4	151.7	154.8	147.9	149.8	153.1	5.4	148.6	149.7	150.0	145.0	149.9	148.6	7.2	143.2	144.0	143.3	144.0	143.6	
12-2-A	2.493	2.279	142.2	146.3	146.3	147.1	146.2	145.6	4.7	144.0	143.8	143.6	144.3	143.0	143.7	6.8	141.9	140.4	140.8	142.1	141.3	
12-2-B	2.493	2.283	142.5	152.0	150.6	151.0	149.2	150.7	5.4	149.5	147.5	149.0	146.0	147.9	148.0	7.4	146.0	145.5	145.0	144.9	145.4	
12-2-C	2.493	2.303	143.7	146.1	144.3	140.5	143.1	146.3	4.6	142.8	141.8	144.3	142.0	142.7	142.7	7.1	145.1	144.9	144.9	144.5	144.9	
12-2-D	2.493	2.246	140.2	141.7	141.8	140.9	141.3	141.4	3.1	139.8	139.6	139.0	138.8	139.8	139.4	5.4	138.7	140.3	137.5	138.3	138.7	
12-3-A	2.472	2.305	143.8	145.2	143.6	145.3	145.3	143.1	4.2	142.3	141.5	142.1	142.1	140.4	141.7	6.6	144.7	143.6	144.4	142.7	143.9	
12-3-B	2.472	2.328	145.3	147.2	146.4	146.3	146.9	148.0	3.2	143.3	143.1	143.5	144.4	144.6	143.8	5.1	144.3	143.5	143.9	145.0	144.2	
12-3-C	2.472	2.266	141.4	142.4	144.0	146.0	147.9	146.7	7.4	144.4	146.3	145.7	147.4	144.2	145.6	10.1	141.9	142.2	143.3	142.3	142.4	
12-3-D	2.472	2.288	142.8	141.4	145.5	143.1	137.9	137.5	4.1	140.4	136.6	139.7	146.9	139.9	140.7	8.2	139.0	139.2	139.9	141.7	140.0	
12-4-A	2.486	2.288	142.8	145.0	147.8	144.5	145.3	148.8	4.6	144.6	146.6	144.3	146.5	144.0	145.2	7.8	141.8	142.4	142.4	142.4	142.3	
12-4-B	2.486	2.255	140.7	144.2	145.4	146.6	143.3	143.8	5.3	142.5	141.3	143.4	144.7	138.8	142.1	7.6	141.6	138.9	142.3	141.5	141.1	
12-4-C	2.486	2.308	144.0	147.8	146.2	146.1	140.4	142.6	4.4	144.6	142.0	141.5	142.3	143.0	142.7	6.8	141.2	143.8	143.6	144.7	143.3	
12-4-D	2.486	2.309	144.1	145.1	143.4	142.7	145.7	144.2	4.6	142.9	142.1	142.5	143.0	138.2	141.7	6.9	141.6	138.3	141.4	140.8	140.5	
13-1-A	2.494	2.333	145.6	146.7	147.8	148.2	146.7	147.2	3.7	144.1	145.2	144.7	143.8	144.5	144.5	5.8	145.8	145.4	145.0	146.0	145.6	
13-1-B	2.494	2.343	146.2	147.6	146.1	147.7	146.7	146.7	3.3	145.1	143.0	144.2	143.7	142.8	143.8	5.2	144.9	145.7	144.7	145.3	145.2	
13-1-C	2.494	2.345	146.3	147.9	145.7	147.6	147.9	148.2	3.7	144.7	142.1	144.4	144.5	143.8	143.9	5.7	146.0	143.6	144.2	143.6	144.4	
13-1-D	2.494	2.301	143.6	137.3	137.3	139.0	138.6	137.3	4.4	140.0	143.4	140.4	141.5	139.9	141.0	6.9	140.1	140.0	139.1	139.7	139.7	
13-2-A	2.483	2.308	144.0	142.9	140.6	141.7	142.3	141.9	5.6	141.7	144.1	142.3	143.8	143.8	143.1	8.8	143.6	144.8	143.6	144.0	144.0	
13-2-B	2.483	2.302	143.6	138.2	139.8	138.7	139.4	138.8	4.9	139.3	140.8	139.8	139.7	139.8	139.9	7.8	138.7	138.8	138.6	138.9	138.8	
13-2-C	2.483	2.319	144.7	135.2	138.4	136.8	139.4	138.1	5.2	138.2	141.0	139.1	140.9	138.9	139.6	8.0	135.3	134.7	136.3	135.8	135.5	
13-2-D	2.483	2.268	141.5	144.3	143.7	142.8	142.0	144.3	5.4	146.0	142.6	143.3	145.6	142.9	144.1	8.2	141.5	142.1	142.2	141.3	141.8	
13-3-A	2.485	2.356	147.0	144.2	131.9	144.0	143.2	143.7	4.4	144.4	143.9	145.0	143.6	144.5	144.3	6.1	146.8	146.9	145.7	146.9	146.6	
13-3-B	2.485	2.328	145.3	138.3	138.0	139.3	141.9	136.7	4.9	144.2	141.5	142.7	144.6	138.4	142.3	7.7	142.0	141.4	141.1	142.0	141.6	
13-3-C	2.485	2.314	144.4	142.0	141.2	140.1	140.4	142.1	4.3	141.8	141.7	141.4	142.2	141.9	141.8	6.9	142.8	142.7	143.0	142.4	142.7	
13-3-D	2.485	2.316	144.5	139.1	138.9	142.0	139.6	140.2	5.0	139.7	140.9	138.8	141.6	140.9	140.4	7.8	141.6	140.3	140.9	141.0	141.0	
13-4-A	2.475	2.308	144.0	141.6	144.4	143.9	142.4	143.4	3.9	142.8	143.3	143.1	142.3	143.0	142.9	6.4	143.0	143.9	142.6	143.9	143.4	